

# Product Specification Sheet

## NS-SFP+DXXL80D

RoHS Compliant 10Gb/s SFP+ DWDM 80km Optical Transceiver



## Особенности

- Поддержка скоростей от 9,95 до 11,3 Гбит/с.
- Дуплексный разъем LC
- Форм-фактор SFP+ с возможностью «горячей» замены
- Лазер Cooled EML и приемник APD
- Подходит для работы по SMF на расстоянии до 80 км.
- Низкое энергопотребление < 1,5 Вт
- Разнос каналов 100 ГГц
- Интерфейс цифрового диагностики сигнала
- Оптический интерфейс, совместимый с ITU-T 694.1 и G.698.1.
- Электрический интерфейс соответствует стандартам SFF-8431 и SFF-8432.
- Рабочая температура корпуса:  
Коммерческая: от 0 до 70 °С,  
Промышленная: от -40 до 85 °С

## Применение

- 10G Ethernet
- 2x, 4x, 8x Fiber Channel
- ITU-T G.698.1

NewNets NS-SFP+DXXL80D Трансиверы Enhanced Small Form Factor Pluggable SFP+ предназначены для организации каналов 10-Gigabit Ethernet на расстоянии до 80 км по одномодовому волокну. Соответствуют стандартам SFF-8431, SFF-8432 и ITU-T G.698.1. Конструкции приемопередатчиков оптимизированы для обеспечения высокой производительности и экономичности.

Трансивер состоит из двух секций: секция передатчика включает в лазер Cooled-EML. А секция приемника состоит из фотодиода APD, интегрированного с ТИА. Все модули соответствуют требованиям лазерной безопасности класса I. Функции цифровой диагностики доступны через 2-проводной последовательный интерфейс, в соответствии с SFF-8472, который обеспечивает доступ в реальном времени к рабочим параметрам устройства, таким как температура приемопередатчика, ток смещения лазера, передаваемая оптическая мощность, принимаемая оптическая мощность и напряжение питания приемопередатчика.



## Product Channel Selection

Channel#	Product Part No.	Frequency (THz)	Center Wavelength (nm)
17	NS-SFP+D17L80D	191.7	1563.86
18	NS-SFP+D18L80D	191.8	1563.05
19	NS-SFP+D19L80D	191.9	1562.23
20	NS-SFP+D20L80D	192.0	1561.42
21	NS-SFP+D21L80D	192.1	1560.61
22	NS-SFP+D22L80D	192.2	1559.79
23	NS-SFP+D23L80D	192.3	1558.98
24	NS-SFP+D24L80D	192.4	1558.17
25	NS-SFP+D25L80D	192.5	1557.36
26	NS-SFP+D26L80D	192.6	1556.55
27	NS-SFP+D27L80D	192.7	1555.75
28	NS-SFP+D28L80D	192.8	1554.94
29	NS-SFP+D29L80D	192.9	1554.13
30	NS-SFP+D30L80D	193.0	1553.33
31	NS-SFP+D31L80D	193.1	1552.52
32	NS-SFP+D32L80D	193.2	1551.72
33	NS-SFP+D33L80D	193.3	1550.92
34	NS-SFP+D34L80D	193.4	1550.12
35	NS-SFP+D35L80D	193.5	1549.32
36	NS-SFP+D36L80D	193.6	1548.51
37	NS-SFP+D37L80D	193.7	1547.72
38	NS-SFP+D38L80D	193.8	1546.92
39	NS-SFP+D39L80D	193.9	1546.12
40	NS-SFP+D40L80D	194.0	1545.32
41	NS-SFP+D41L80D	194.1	1544.53
42	NS-SFP+D42L80D	194.2	1543.73
43	NS-SFP+D43L80D	194.3	1542.94
44	NS-SFP+D44L80D	194.4	1542.14
45	NS-SFP+D45L80D	194.5	1541.35
46	NS-SFP+D46L80D	194.6	1540.56
47	NS-SFP+D47L80D	194.7	1539.77
48	NS-SFP+D48L80D	194.8	1538.98
49	NS-SFP+D49L80D	194.9	1538.19
50	NS-SFP+D50L80D	195.0	1537.40
51	NS-SFP+D51L80D	195.1	1536.61
52	NS-SFP+D52L80D	195.2	1535.82
53	NS-SFP+D53L80D	195.3	1535.04
54	NS-SFP+D54L80D	195.4	1534.25
55	NS-SFP+D55L80D	195.5	1533.47
56	NS-SFP+D56L80D	195.6	1532.68
57	NS-SFP+D57L80D	195.7	1531.90
58	NS-SFP+D58L80D	195.8	1531.12



Оборудование, решение и реализация  
DWDM проектов

59	NS-SFP+D59L80D	195.9	1530.33
60	NS-SFP+D60L80D	196.0	1529.55
61	NS-SFP+D61L80D	196.1	1528.77
62	NS-SFP+D62L80D	196,2	1527.99
63	NS-SFP+D63L80D	196,3	1527.22
64	NS-SFP+D64L80D	196,4	1526.44
65	NS-SFP+D65L80D	196,5	1525.56

## Functional Diagram

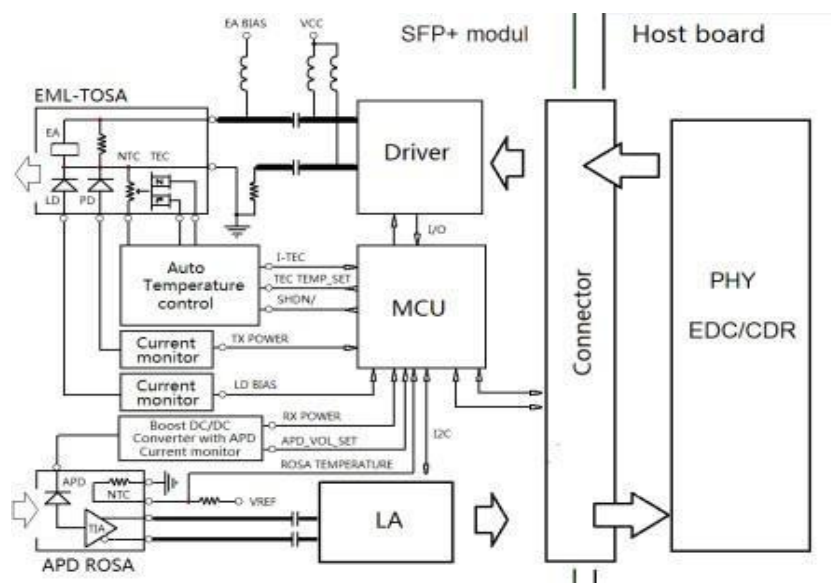

## Absolute Maximum Ratings

Parameter	Symbol	Min.	Max.	Unit	Note
Supply Voltage	Vcc	-0.5	4.0	V	
Storage Temperature	Ts	-40	85	°C	
Relative Humidity	RH	0	85	%	
Receiver Damage Threshold	RXDamage	+5		dBm	

**Note:** Stress in excess of the maximum absolute ratings can cause permanent damage to the transceiver.

## General Operating Characteristics

Parameter	Symbol	Min.	Typ	Max.	Unit	Note
Data Rate	DR	9.95	10.3125	11.3	Gb/s	
Supply Voltage	Vcc	3.13	3.3	3.47	V	
Supply Current	Iccs			450	mA	
Operating Case Temp.	Tc	0		70	°C	
	Ti	-40		85		

**Electrical Characteristics** ( $T_{OP(C)} = 0 \text{ to } 70 \text{ }^{\circ}\text{C}$ ,  $T_{OP(I)} = -40 \text{ to } 85 \text{ }^{\circ}\text{C}$ ,  $V_{CC} = 3.13 \text{ to } 3.47 \text{ V}$ )

Parameter	Symbol	Min.	Typ	Max.	Unit	Note
<b>Transmitter</b>						
Differential data input swing	$V_{IN,PP}$	120		850	mV <sub>pp</sub>	1
Transmit Disable Voltage	$V_D$	$V_{CC}-0.8$		$V_{CC}$	V	
Transmit Enable Voltage	$V_{EN}$	V <sub>ee</sub>		$V_{ee}+0.8$		
Input differential impedance	$R_{in}$		100		$\Omega$	
<b>Receiver</b>						
Differential data output swing	$V_{out,pp}$	300		850	mV <sub>pp</sub>	1
Output rise time and fall time	$T_r, T_f$	28			Ps	2
LOS asserted	$V_{LOS\_F}$	$V_{CC}-0.8$		$V_{CC}$	V	3
LOS de-asserted	$V_{LOS\_N}$	V <sub>ee</sub>		$V_{ee}+0.8$	V	3

**Notes:**

- Internally AC coupled. Data pins connect directly to the CDR.
- 20 – 80%. Measured with Module Compliance Test Board and OMA test pattern. Use of four 1's and four 0's sequence in the PRBS 9 is an acceptable alternative.
- LOS is an open collector output. Should be pulled up with 4.7k $\Omega$  – 10k $\Omega$  on the host board. Normal operation is logic 0; loss of signal is logic 1.

**Optical Characteristics** ( $T_{OP(C)} = 0 \text{ to } 70 \text{ }^{\circ}\text{C}$ ,  $T_{OP(I)} = -40 \text{ to } 85 \text{ }^{\circ}\text{C}$ ,  $V_{CC} = 3.13 \text{ to } 3.47 \text{ V}$ )

Parameter	Symbol	Min.	Typ	Max.	Unit	Note
<b>Transmitter</b>						
Center Wavelength	$\lambda_c$	1528.77		1563.86	nm	
Center Wavelength (End of Life)	$\lambda_{c\_EOL}$		$\lambda_c \pm 100\text{pm}$			
Ave. output power (Enabled)	$P_{AVE}$	0		5	dBm	1
Side-Mode Suppression Ratio	SMSR	30			dB	
Extinction Ratio	ER	8.2			dB	
RMS spectral width	$\Delta\lambda$			1	nm	
Rise/Fall time (20%~80%)	$T_r/T_f$			50	ps	
Relative Intensity Noise	$R_{IN}$			-128	dB/Hz	
<b>Receiver</b>						
Operating Wavelength	$\lambda$	1260		1600	nm	
Sensitivity	$P_{SEN1}$			-23	dBm	2
Overload	$P_{AVE}$	-7			dBm	
LOS Assert	$P_a$	-35			dBm	
LOS De-assert	$P_d$			-24	dBm	
LOS Hysteresis	$P_d-P_a$	0.5			dB	

**Notes:**

- Measured  $2^{31-1}$  PRBS@10.3125G
- Measured with worst ER=8.2dB;  $2^{31-1}$  PRBS@10.3125G

## Pin Defintion And Functions

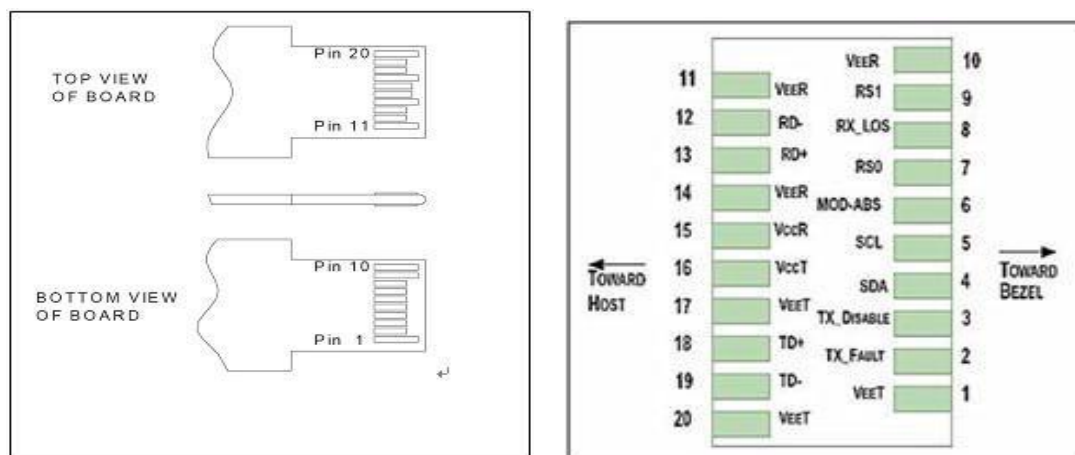

Pin	Symbol	Name/Description
1	VEET [1]	Transmitter Ground
2	Tx_FAULT [2]	Transmitter Fault
3	Tx_DIS [3]	Transmitter Disable. Laser output disabled on high or open
4	SDA [2]	2-wire Serial Interface Data Line
5	SCL [2]	2-wire Serial Interface Clock Line
6	MOD_ABS [4]	Module Absent. Grounded within the module
7	RS0	Rate Select 0
8	RX_LOS [2]	Loss of Signal indication. Logic 0 indicates normal operation
9	RS1	Rate Select 1
10	VEER [1]	Receiver Ground
11	VEER [1]	Receiver Ground
12	RD-	Receiver Inverted DATA out. AC Coupled
13	RD+	Receiver DATA out. AC Coupled
14	VEER [1]	Receiver Ground
15	VCCR	Receiver Power Supply
16	VCCT	Transmitter Power Supply
17	VEET [1]	Transmitter Ground
18	TD+	Transmitter DATA in. AC Coupled
19	TD-	Transmitter Inverted DATA in. AC Coupled
20	VEET [1]	Transmitter Ground

### Notes:

1. Module circuit ground is isolated from module chassis ground within the module.
2. should be pulled up with 4.7k – 10k ohms on host board to a voltage between 3.15V and 3.6V.
3. Tx\_Disable is an input contact with a 4.7 kΩ to 10 kΩ pullup to VccT inside the module.
4. Mod\_ABS is connected to VeeT or VeeR in the SFP+ module. The host may pull this contact up to Vcc\_Host with a resistor in the range 4.7 kΩ to 10 kΩ. Mod\_ABS is asserted “High” when the SFP+ module is physically absent from a host slot.

## Serial Interface for ID and Digital Diagnostic Monitor

The NS-SFP+DXXL80D transceiver support the 2-wire serial communication protocol as defined in the SFP+ MSA. The standard SFP+ serial ID provides access to identification information that describes the transceiver's capabilities, standard interfaces, manufacturer, and other information. Additionally, This SFP+ transceivers provide an enhanced digital diagnostic monitoring interface, which allows real-time access to device operating parameters such as transceiver temperature, laser bias current, transmitted optical power, received optical power and transceiver supply voltage. It also defines a sophisticated system of alarm and warning flags, which alerts end-users when particular operating parameters are outside of a factory set normal range.

The SFP MSA defines a 256-byte memory map in EEPROM that is accessible over a 2-wire serial interface at the 8 bit address 1010000X(A0h), so the originally monitoring interface makes use of the 8 bit address(A2h), so the originally defined serial ID memory map remains unchanged. The structure of the memory map is shown in Table1.

2 wire address 1010000X (A0h)		2 wire address 1010001X (A2h)	
Address	Information	Address	Information
0~95	Serial ID Defined by SFP MSA (96 bytes)	0~55	Alarm and Warning Thresholds (56 bytes)
		56~95	Calibration Constants (40 bytes)
96~127	Vendor Specific (32 bytes)	96~119	Real Time Diagnostic Interface (24 bytes)
		120~127	Vender Specific (8 bytes)
128~255	Reserved,SFF8079 (128 bytes)	128~247	User Writable EEPROM (120 bytes)
		248~255	Vender Specific (8 bytes)

Table 1. Digital Diagnostic Memory Map (Specific Data Field Descriptions)

## Digital Diagnostic Specifications

The NS-SFP+DXXL80D transceivers can be used in host systems that require either internally or externally calibrated digital diagnostics.

Parameter	Symbol	Units	Min.	Max.	Accuracy	Note
Transceiver temperature	DTemp-E	°C	-10	+90	±5°C	1,2
Transceiver supply voltage	DVoltage	V	2.8	4.0	±3%	
Transmitter bias current	DBias	mA	2	127	±10%	3
Transmitter output power	DTx-Power	dBm	-2	+7	±2dB	
Receiver average input power	DRx-Power	dBm	-25	0	±2dB	

### Notes:

1. When Operating temp.=0~70 °C,the range will be min=-5,Max=+75
2. Internally measured
3. The accuracy of the Tx bias current is 10% of the actual current from the laser driver to the laser



## Typical Interface Circuit

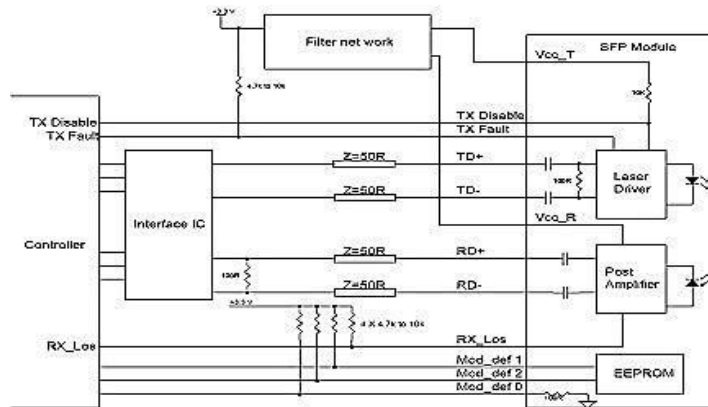

## Recommended power supply filter

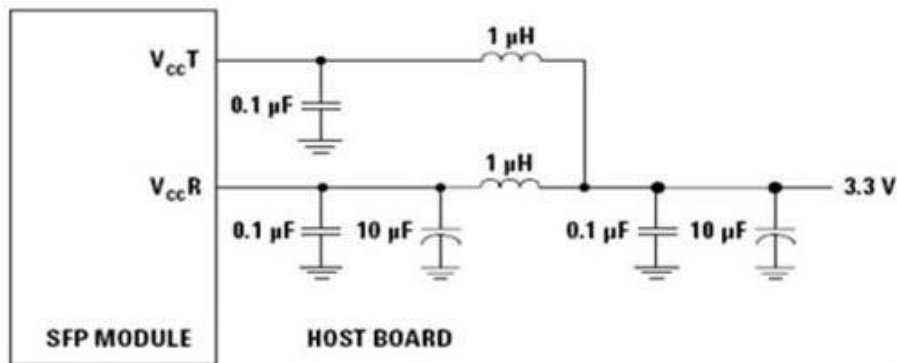

### Note:

Inductors with DC resistance of less than 1Ω should be used in order to maintain the required voltage at the SFP input pin with 3.3V supply voltage. When the recommended supply filtering network is used, hot plugging of the SFP transceiver module will result in an inrush current of no more than 30 mA greater than the steady state value

## Package Dimensions

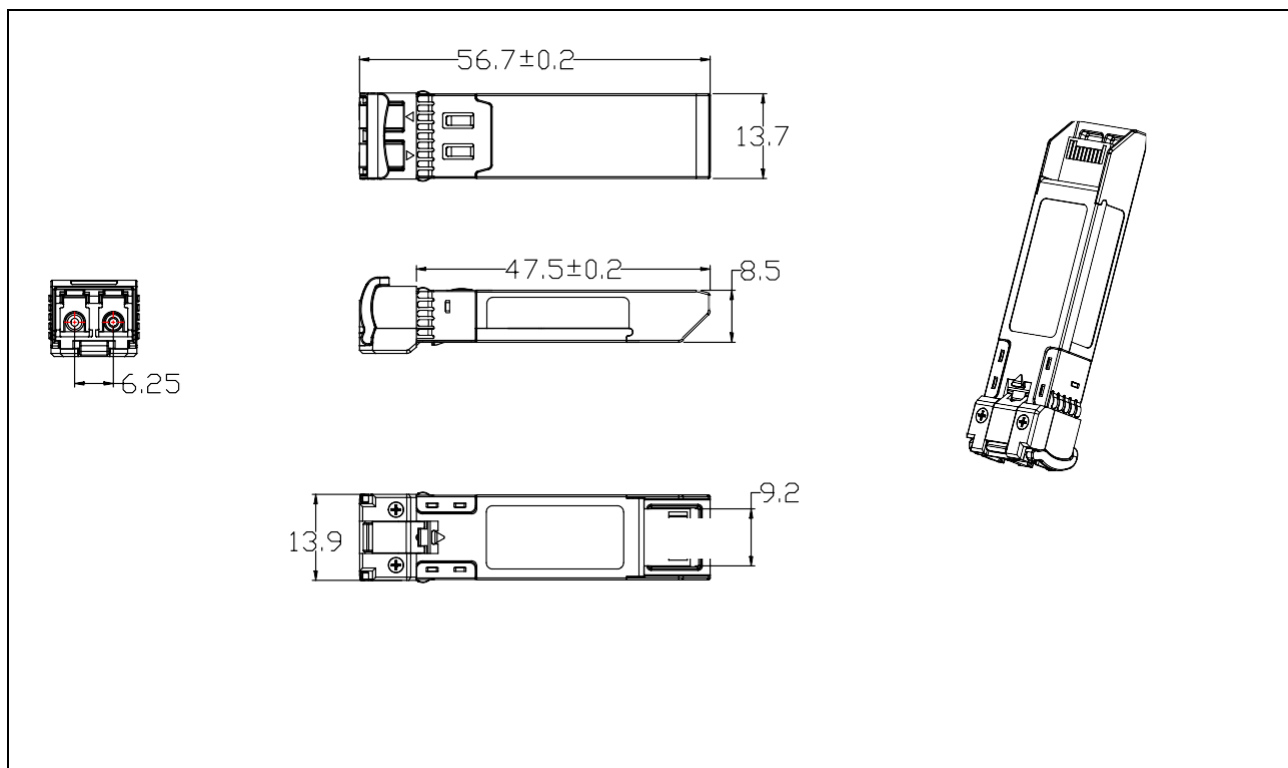

## Ordering Information

Part Number	Description
NS-SFP+DXXL80D	SFP+, 9.95 to 11.3Gb/s, DWDM wavelengths, 80km, 0~70°C, with Digital Diagnostic Monitor
NS-SFP+DXXL80D	SFP+, 9.95 to 11.3Gb/s, DWDM wavelengths, 80km, -40~85°C, with Digital Diagnostic Monitor