

Оптический трансивер SFP+ 10G DWDM 40KM

Features

- Compliant with SFF-8431 and IEEE802.3ae
- Suitable for use in 100GHz channel spacing DWDM systems
- Data rate selectable $\leq 4.25\text{Gbps}$ or 9.95Gbps to 10.3Gbps bit rates
- Cooled EML transmitter and PIN receiver
- link length up to 40km
- Low Power Dissipation 1.5W Maximum
- -5°C to 70°C Operating Case Temperature
- Single 3.3V power supply
- Diagnostic Performance Monitoring of module temperature, supply
- Voltages, laser bias current, transmit optical power, receive optical power
- RoHS compliant and lead free



Applications

- 10GBASE-ER/EW (with/without FEC)
- 10G Fiber Channel (with/without FEC)

Description

SFP+ DWDM Transceiver is designed for 10GBASE, and 8.5G/10G Fiber- Channel applications.

The transceiver consists of two sections: The transmitter section incorporates a cooled EML laser. And the receiver section consists of a PIN photodiode integrated with a TIA. All modules satisfy class I laser safety requirements. Digital diagnostics functions are available via a 2-wire serial interface, as specified in SFF-8472, which allows real-time access to device operating parameters such as transceiver temperature, laser bias current, transmitted optical power, received optical power and transceiver supply voltage.

Absolute Maximum Rating

Parameter	Symbol	Min	Max	Unit
Supply Voltage	Vcc	-0.5	3.8	V
Storage Temperature	Tst	-40	85	°C
Relative Humidity	Rh	0	85	%

Operating Conditions

Parameter	Symbol	Min	Typical	Max	Unit
Supply Voltage	Vcc	3.13	3.3	3.47	V
Supply current	Icc		360	450	mA
Operating Case temperature	Tca	-5	-	70	°C
Module Power Dissipation	Pm	-	1.2	1.5	W

Notes:

[1] Supply current is shared between VCCTX and VCCR_X.

[2] In-rush is defined as current level above steady state current requirements.

Transmitter Specifications – Optical

Parameter	Symbol	Min	Typical	Max	Unit
Center Wavelength (SOL) Δ	λ_c	$\lambda_c - 25$	λ_c	$\lambda_c + 25$	pm
Center Wavelength (EOL) \blacktriangle	λ_c	$\lambda_c - 100$	λ_c	$\lambda_c + 100$	pm
Optical OMA Power	Pom	-1.7			dBm
Side Mode Suppression Ratio	SMSR	30	-	-	dB
Optical Transmit Power (disabled)	PTX_DISABLE	-	-	-30	dBm
Extinction Ratio	ER	8.2		-	dB
RIN ₂₁ OMA [1]				-128	dB/Hz
Optical Return Loss Tolerance				21	dB

Notes:

[1] RIN measurement is made with a return loss at 21 dB.

Δ Laser- Start of Life

\blacktriangle Laser End of life

Transmitter Specifications – Electrical

Parameter	Symbol	Min	Typical	Max	Unit
Data Rate	Mra	-	10.3	11.3	Gbps
Input differential impedance	Rim	-	100	-	Ω
Differential data Input	VtxDIFF	120	-	850	mV
Transmit Disable Voltage	VD	2.0	-	Vcc3+0.3	V
Transmit Enable Voltage	Ven	0	-	+0.8	V
Transmit Disable Assert Time	Vn	-	-	100	us

Receiver Specifications – Optical

Parameter	Symbol	Min	Typical	Max	Unit
Input Operating Wavelength	λ	1260	-	1620	nm
Average receive power		-	-	-1.0	dBm
Receiver sensitivity in OMA		-	-	-14.1	dBm
Stressed receiver sensitivity in OMA[1]				-11.3	dBm
Maximum Input Power	RX-overload	-	-	-1	dBm
Reflectance	Rrx	-	-	-27	dB
Loss of Signal Asserted		-25	-	-	dBm
LOS De-Asserted		-	-	-16	dBm
LOS Hysteresis		0.5	-	-	dB

Notes:

[1] Measured with conformance test signal for BER = 10⁻¹². The stressed sensitivity values in the table are for system level BER measurements which include the effects of CDR circuits. It is recommended that at least 0.4 dB additional margin be allocated if component level measurements are made without the effects of CDR circuits.

Receiver Specifications – Electrical

Parameter	Symbol	Min	Typical	Max	Unit
Data Rate	Mra	-	10.3	11.3	Gbps
Differential Output Swing	Vout P-P	350	-	850	mV
Rise/Fall Time	Tr / Tf	24	-	-	ps
Loss of Signal -Asserted	VOH	2	-	Vcc3+0.3-	V
Loss of Signal -Negated	VOL	0	-	+0.4	V

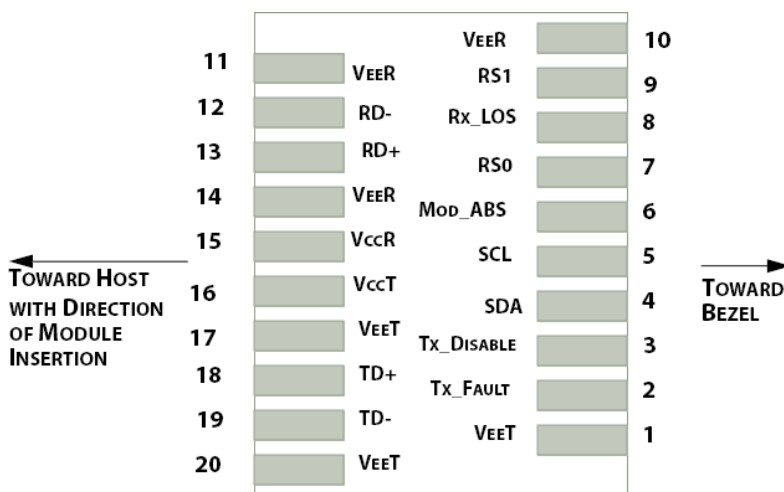

Figure1.Electrical Pin-out Details

Pin Descriptions

Pin	Symbol	Name/Description
1	VEET [1]	Transmitter Ground
2	Tx_FAULT [2]	Transmitter Fault
3	Tx_DIS [3]	Transmitter Disable. Laser output disabled on high or open
4	SDA [2]	2-wire Serial Interface Data Line
5	SCL [2]	2-wire Serial Interface Clock Line
6	MOD_ABS [4]	Module Absent. Grounded within the module
7	RS0 [5]	RS0 for Rate Select: Open or Low = Module supports ≤ 4.25 Gbps High = Module supports 9.95 Gb/s to 10.3125 Gb/s
8	RX_LOS [2]	Loss of Signal indication. Logic 0 indicates normal operation
9	RS1 [5]	No connection required
10	VEER [1]	Receiver Ground
11	VEER [1]	Receiver Ground
12	RD-	Receiver Inverted DATA out. AC Coupled
13	RD+	Receiver DATA out. AC Coupled
14	VEER [1]	Receiver Ground
15	VCCR	Receiver Power Supply
16	VCCT	Transmitter Power Supply
17	VEET [1]	Transmitter Ground
18	TD+	Transmitter DATA in. AC Coupled
19	TD-	Transmitter Inverted DATA in. AC Coupled
20	VEET [1]	Transmitter Ground

Notes:

[1] Module circuit ground is isolated from module chassis ground within the module.

[2].should be pulled up with 4.7k – 10k ohms on host board to a voltage between 3.15V and 3.6V.

[3]Tx_Disable is an input contact with a 4.7 k Ω to 10 k Ω pullup to VccT inside the module.

[4] Mod_ABS is connected to VeeT or VeeR in the SFP+ module. The host may pull this contact up to Vcc_Host with a resistor in the range 4.7 k Ω to 10 k Ω . Mod_ABS is asserted “High” when the SFP+ module is physically absent from a host slot.

[5] RS0 and RS1 are module inputs and are pulled low to VeeT with > 30 k Ω resistors in the module.



C-band λ c Wavelength Guide

ITU Channel Product Code	Frequency(THz)	Wavelength	ITU Channel Product Code	Frequency(THz)	Wavelength
17	191.7	1563.86	40	194.0	1545.32
18	191.8	1563.05	41	194.1	1544.53
19	191.9	1562.23	42	194.2	1543.73
20	192.0	1561.42	43	194.3	1542.94
21	192.1	1560.61	44	194.4	1542.14
22	192.2	1559.79	45	194.5	1541.35
23	192.3	1558.98	46	194.6	1540.56
24	192.4	1558.17	47	194.7	1539.77
25	192.5	1557.36	48	194.8	1538.98
26	192.6	1556.55	49	194.9	1538.19
27	192.7	1555.75	50	195.0	1537.40
28	192.8	1554.94	51	195.1	1536.61
29	192.9	1554.13	52	195.2	1535.82
30	193.0	1553.33	53	195.3	1535.04
31	193.1	1552.52	54	195.4	1534.25
32	193.2	1551.72	55	195.5	1533.47
33	193.3	1550.92	56	195.6	1532.68
34	193.4	1550.12	57	195.7	1531.90
35	193.5	1549.32	58	195.8	1531.12
36	193.6	1548.51	59	195.9	1530.33
37	193.7	1547.72	60	196.0	1529.55
38	193.8	1546.92	61	196.1	1528.77
39	193.9	1546.12			

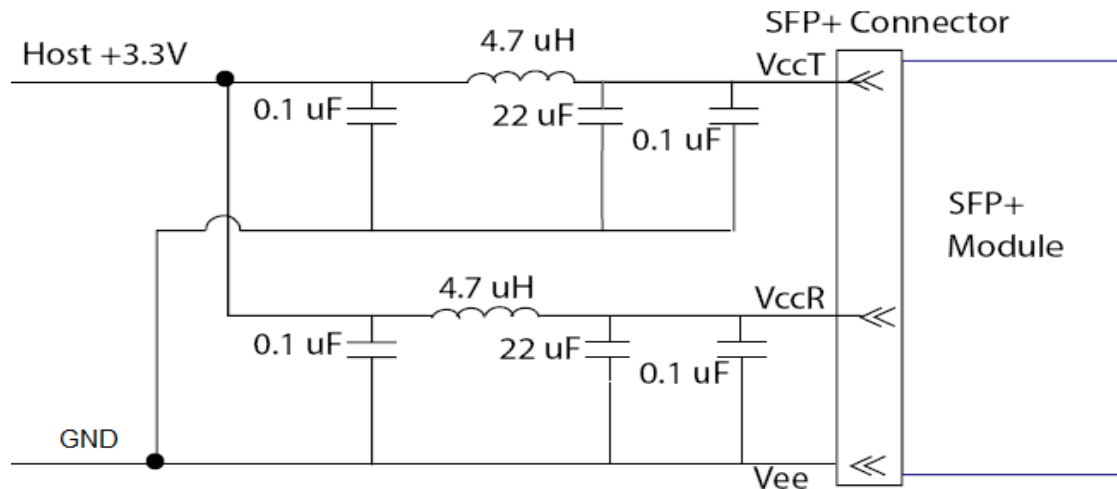

Figure2. Host Board Power Supply Filters Circuit

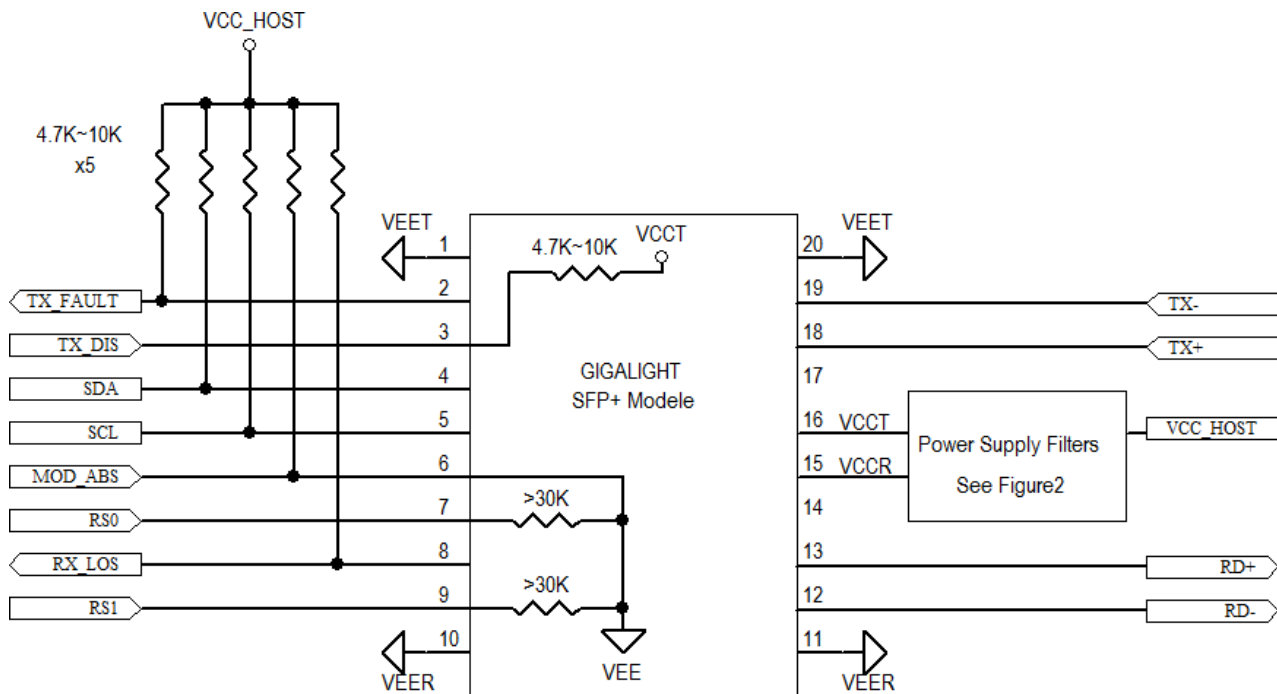

Figure3. Host-Module Interface

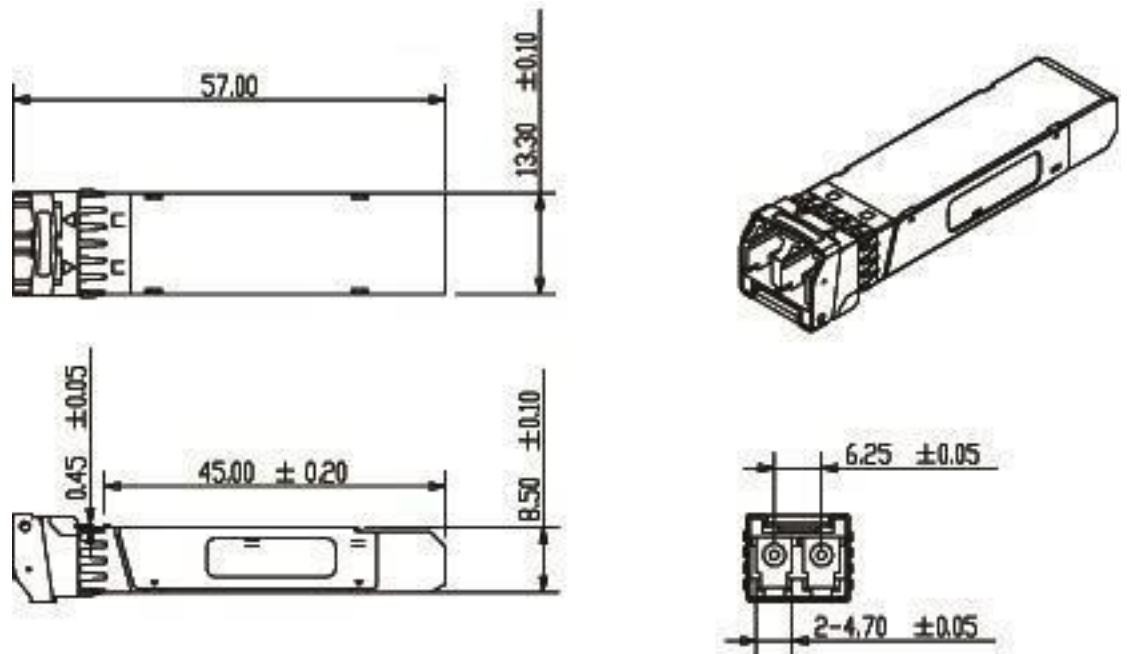

Figure6. Mechanical Specifications